

Journal of Cybernetics and Informatics

published by

**Slovak Society for
Cybernetics and Informatics**

Volume 11, 2010

<http://www.sski.sk/casopis/index.php> (home page)

ISSN: 1336-4774

CONTROL OF ELECTRONIC THROTTLE VALVE POSITION OF SI ENGINE

Marek Honek, Slawomir Wojnar, Peter Šimončíč and Boris Rohaľ-Ikiv

Slovak University of Technology, Faculty of Mechanical Engineering
Námestie Slobody 17, 812 31 Bratislava, Slovak Republic
e-mail: marek.honek@stuba.sk

Abstract: The paper deals with an electronic throttle control problem. The proposed method applies a discrete PI controller with parameters scheduling and feedforward controller working together.

Keywords: electronic throttle, PI controller with parameters scheduling, feedforward controller, SI combustion engine, dSpace

1 INTRODUCTION AND PRELIMINARIES

The electronic throttle (ET) is a valve used in vehicles to control the air flow into the engine combustion system. The ET (shown on the Figure 1.1) consists of a DC drive, a gearbox, a valve plate, a dual return spring and a position sensor (potentiometer). The heart of this system is a plate swung by the use of the DC motor. There is also a spring which provides a torque working against the DC motor. This construction has multiple sources of nonlinearity, and the use of non-linear control theory is addressed as well. Experimental research allows to apply PI controller with scheduling of parameters and a feedforward controller in this case. For implementation of control algorithm, the Real Time Windows target has been used.

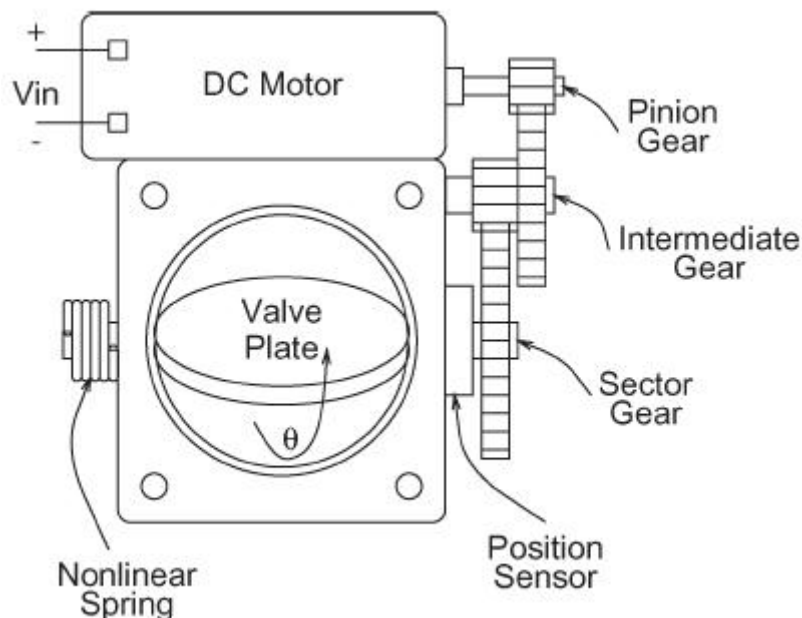

Figure 1.1: Electronic Throttle Body

2 ET MODEL DESCRIPTION

Electrical DC motor can be modeled using a linear differential equation.

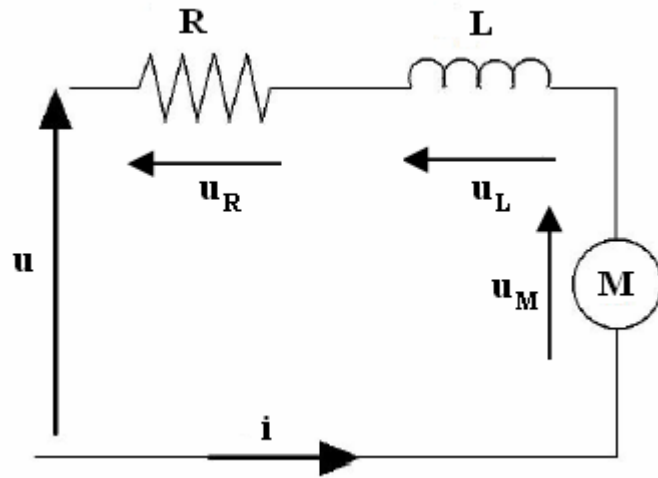

Figure 2.1: Electrical scheme of a DC motor

The sum of voltages in the closed circuit has to be equal to zero, as described by the second Kirchhoff's law:

$$u = Ri + L \frac{di}{dt} + k_e \dot{\phi} \quad (1)$$

where: k_e is electromotive force constant, R is electric resistance, L is electric inductance.

Then equation of motion is in the form:

$$J\ddot{\phi} = M_G - M_{RS} - M_F \quad (2)$$

Torque generated by the motor is proportional to the electric current.

$$M_G = k_e i \quad (3)$$

M_{RS} is the torque acting against M_G and is caused by the returning spring. Stiffness parameter of this spring is a function of a throttle valve position. This is one of the sources of nonlinearity. Spring nonlinearity problem is described in referenced works [R. Grepl, T. Wilson].

M_F is friction torque and consists of two parts, linear (viscous damping) and nonlinear (described in reference works [R. Grepl, T. Wilson]).

3 PUBLISHED ELECTRONIC THROTTLE CONTROL (ETC) APPROACHES

1. In reference work [R. Grepl] PID controller with a friction and spring nonlinearity compensator was used.

2. Discrete PID controller with error threshold for changing β parameter in control law:

$$u(k) = K_p e(k) + \beta K_i \sum_{j=0}^k e(j)T + K_D \frac{e(k) - e(k-1)}{T}, \text{ described in [Q. Weikang].}$$

3. Adaptive PID with Anti-wind-up feature was presented in [Y. Yildiz].

4. MPC robust control algorithm and identification in PWARX (Piece Wise ARX), [M. Vařak].
5. Constrained optimal control, [T. Wilson].

In listed papers different control approaches are used: conventional (different form of PID control) and more sophisticated, based on knowledge of the mathematical model (MPC).

4 PROPOSED CONTROL

The structure of a control system and the used control algorithms are presented in this section. Figure 4.1 depicts a block scheme of the control system: feedforward controller and feedback discrete adaptive PI controller in velocity form.

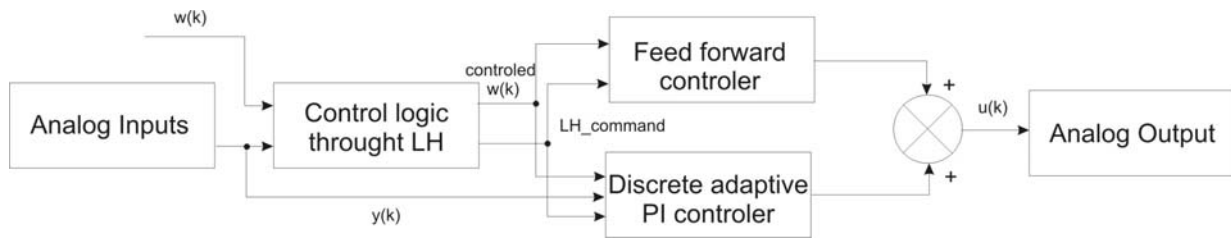

Figure 4.1: Structure of the control system

The control sample time is set to 0.01s in relation to the rate of dynamics of the electronic throttle system. Measurement of the signal of potentiometer is sampled by a frequency of 1kHz and filtered output has the same frequency as the control.

Design of the control system structure which is presented in figure 4.1 is based on practical experience and analysis of some articles. Control of the electronic throttle by using only feedback discrete PI controller shows that action value has three main levels for the whole range of control variable. This fact is used as a knowledge base for feedforward controller designing.

The output voltage signal of the electronic throttle potentiometer has range from 0.51V (closed valve) to 4.59V (opened valve). Voltage level of 0.915V represents Limp Home position (LH). The DC motor is controlled by the PWM signal. This PWM signal is generated by the microcontroller application with H-bridge with the possibility of negative polarization of the DC motor. Duty cycle and polarity is controlled by the voltage signal generated on an analog output of the laboratory PC card. Its range is (0-10)V and the microcontroller application was designed so that voltage of 5.5V sets zero percentage of the duty cycle. Voltage lower than 5.5V closes the valve and higher than voltage 5.5V opens the valve. As mentioned above, three main levels of the action value reach 4V, 5.5V and 7V. Due to this fact, the feedforward controller was added.

We can assume that use of this controller guarantees faster responses when the output of the plant is going through LH position, where the stiffness of the return spring is the highest.

It would be very difficult to design an action law and parameters of the feedback controller, in case that the feedforward controller would change the action value only based on the desired value. The block named Control logic through LH (Figure 4.1) controls the desired value with effect during the transition through LH position. We describe its functionality more precisely below.

It is possible to see principal diagram of the mechanical system, with explanation of the oscillation around the LH position in figure 4.2.

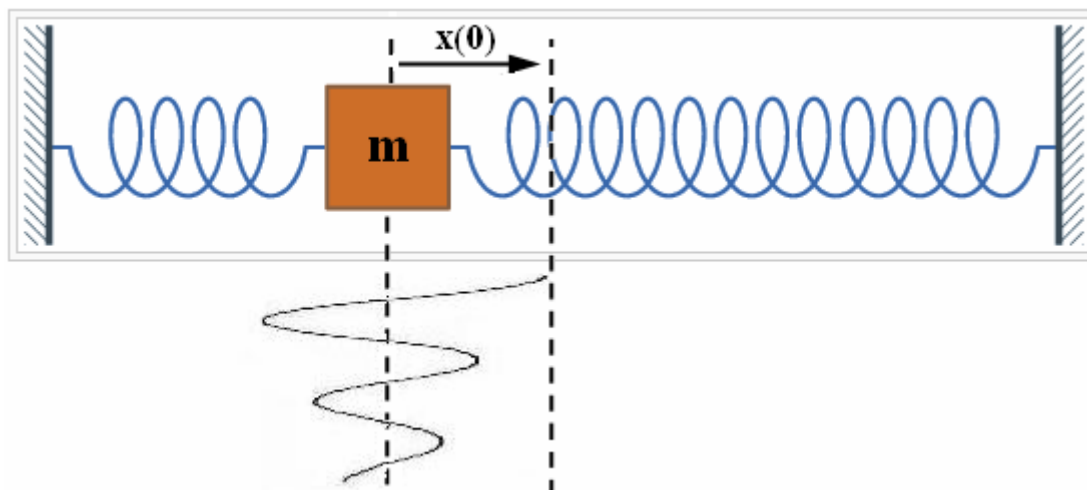

Figure 4.2: Principia diagram of oscillatory system

All problems with throttle control during going up and down through the LH position are caused by oscillatory nature of this phenomenon. If we push mass from equilibrium point to $x(0)$ position like we see in Figure 4.2 and let it go, it will be possible to observe motion of the mass, which can be described by harmonic function.

That is why it was necessary to distinguish throttle plate motion direction. When the throttle goes out of LH position, the spring works against the DC motor but when it goes to LH, the spring and motor work together to reach the LH.

Control logic through LH block (Figure 4.1) works in this way, if new desired value falls down below (or jumps over) LH, controlled_w(k) signal will be set to LH. After the controlled value reaches LH position, LH_command output is set to 1. Now the process is waiting on LH position for time, the length of which is given by exact number of control steps. After that, controlled_w(k) is set to the expected new desired value and LH_command is set to 0. If new desired value does not go through LH, LH_command output will be kept at 0 level and input $w(k)$ will be sent directly to output controlled_w(k). Summing up, process that goes through the LH position has two parts: reaching the LH and then reaching a new desired value.

The feedforward controller has three possible states. If controlled_w(k) is bigger than LH the output is set to 7V, if controlled_w(k) is less than LH the output is set to 4V and in case if LH_command is 1, then output is set to 5.5V.

The function of discrete PI controller depends on level of LH_command signal in a sense, that the discrete PI controller is turned on for its 0 level and it is turned off and initialized in the other case.

Discrete PI velocity controller is used in our feedback control system in the form:

$$u(k) = u(k-1) + \Delta u(k) \quad (4)$$

$$\Delta u(k) = K_p(e(k) - e(k-1)) + K_i e(k) \quad (5)$$

Initial research shows that constant K_p and K_i gains cannot be used because of the overshoot problem (Figure 4.3) in closed-loop step responses. Because of this, it was decided to use scheduling of K_p and K_i .

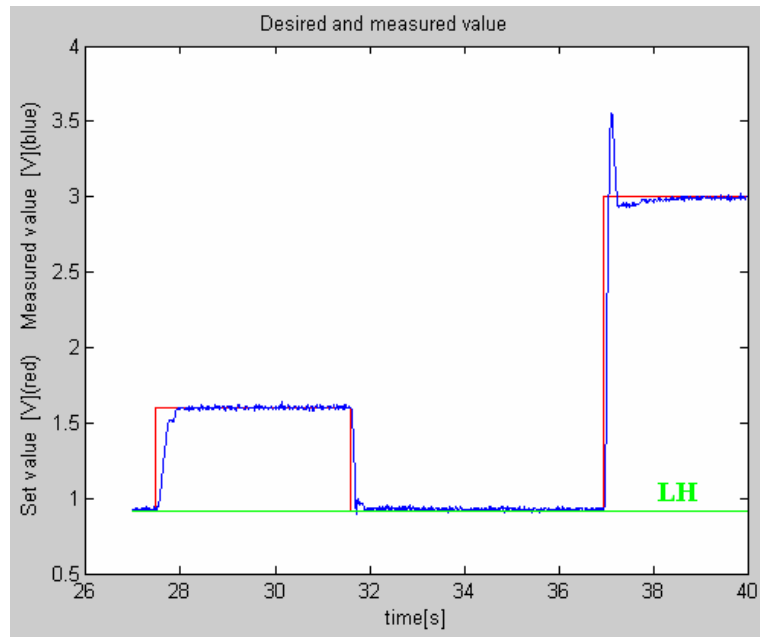

Figure 4.3: Closed-loop step response with discrete PI with constant parameters K_p , K_i .

K_p and K_i gains of discrete adaptive PI controller are changeable and depend on: throttle measured position (over or below LH) and movement direction (throttle opening or closing). There are four areas where K_p and K_i change its values according to linear function (specific in each of this 4 areas). The lines for calculating K_p and K_i parameters are shown in figure 4.3.

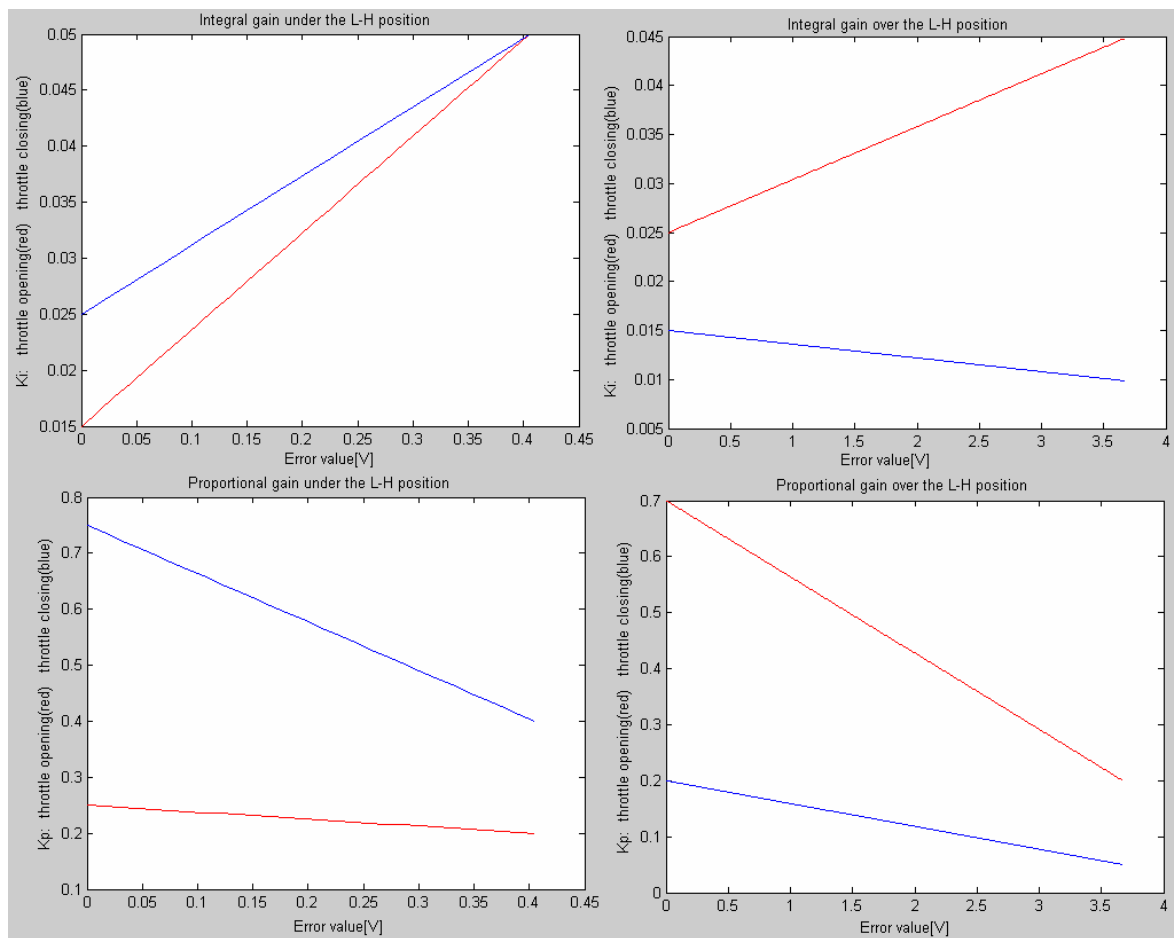

Figure 4.4: K_p and K_i parameters under and over LH position

Independent variable for these functions is the absolute value of actual error with boundaries in error maximum (depend on being over or below LH position). A nonsensitivity area for K_p , K_i scheduling in error equal to zero area is also implemented here.

As the result of this research, next figure 4.5 shows closed-loop response using discrete PI controller with scheduled parameters, as it is described above.

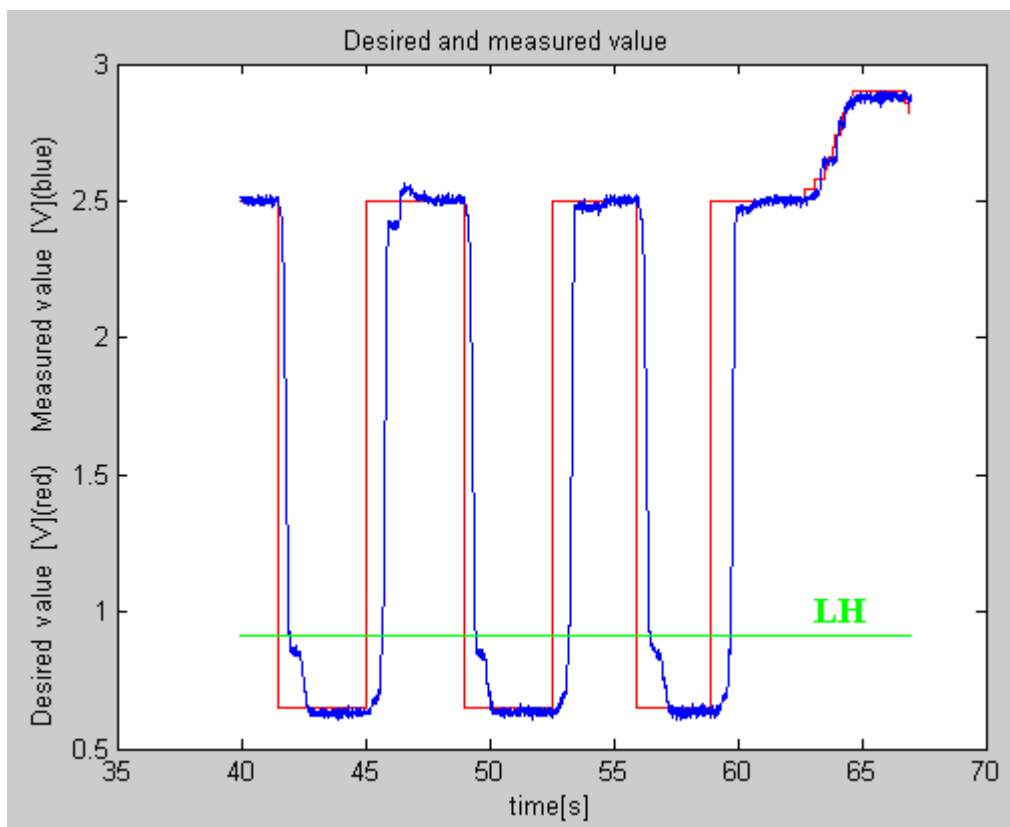

Figure 4.5: Closed-loop step response with discrete PI with scheduled parameters K_p , K_i

5 CONCLUSION

It was necessary to find parameters K_p and K_i and feedforward values in this case, which allow us to reach satisfying loop responses. Even going through LH position caused no problems because of the used algorithm. There is still room for improvement, we intend to apply friction and backlash compensation in future.

ACKNOWLEDGMENTS

The investigation reported in the paper was supported by Slovak Grant Agency APVV, project ID: APVV-0280 – 06 and LPP-0075-09. The support is very gratefully appreciated.

REFERENCES

- R. Grepl, B. Lee.: *Modeling, identification and control of electronic throttle using dSpace tools*, Mechatronics Laboratory, Faculty of Mechanical Engineering, Brno University of Technology
Department of Mechanical and Automotive Engineering, Keimyung University, Korea
- Qian Weikang, Wang Li, Xie Lingjun, Zeng Yifang,(2008): *Practical Solution for Automotive Electronic Throttle Control Based on FPGA*, School of Computer and Electrical Engineering, University of Shanghai for Science and Technology, Shanghai 200093, China,
- Mario Vašak, Mato Baoti'c, Ivan Petrovi'c, Nedjeljko Peri'.(2007): *Hybrid Theory-Based Time-Optimal Control of an Electronic Throttle*, IEEE TRANSACTIONS ON INDUSTRIAL ELECTRONICS, VOL. 54, NO. 3, JUNE 2007
- Yildiray Yildiz (2009): *Adaptive Control of time delay systems and applications to automotive control problem*, Massachusetts Institute of Technology
- Thomas Wilson (2007): *Constrained Optimal Control of an Electronic Throttle Body*, The University of Queensland